

**ISTRUZIONI DI MONTAGGIO**

**IT**

**FITTING INSTRUCTIONS**

**EN**

**INSTRUCTIONS DE MONTAGE**

**FR**

**INSTRUCCIONES DE MONTAJE**

**ES**

**INSTRUÇÕES DE MONTAGEM**

**PO**



**LoveMe**

**LM202**

**Fig. 1/3**

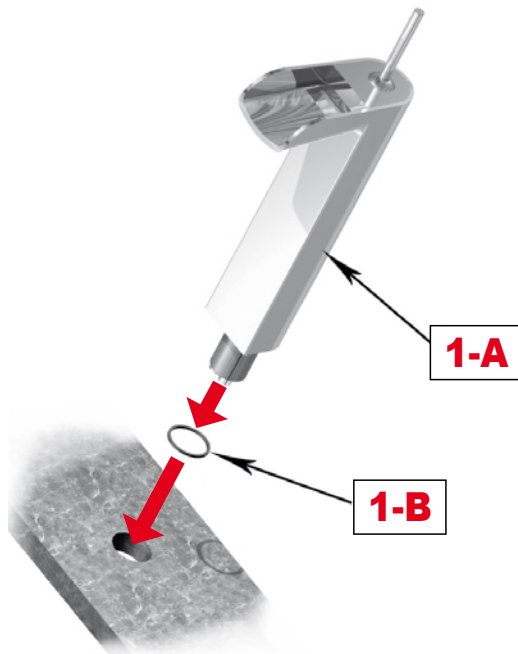

**IT**

Inserire la guarnizione piana **1-B** nel corpo lavabo **1-A**, quindi appoggiare quest'ultimo in prossimità del foro sul piano.

**EN**

Insert the flat gasket **1-B** in the washbasin **1-A**, then place this near the hole on the surface.

**FR**

Introduire le joint plat **1-B** dans le bloc lavabo **1-A** puis poser ce dernier près du trou sur le plan.

**ES**

Introducir la guarnición plana **1-B** en el cuerpo del lavabo **1-A**, y luego apoyar este último cerca del orificio en el plano.

**PO**

Inserir a guarnição plana **1-B** no corpo da pia **1-A**, a seguir apoiá-la próxima ao furo no plano.

**Fig. 2/3**

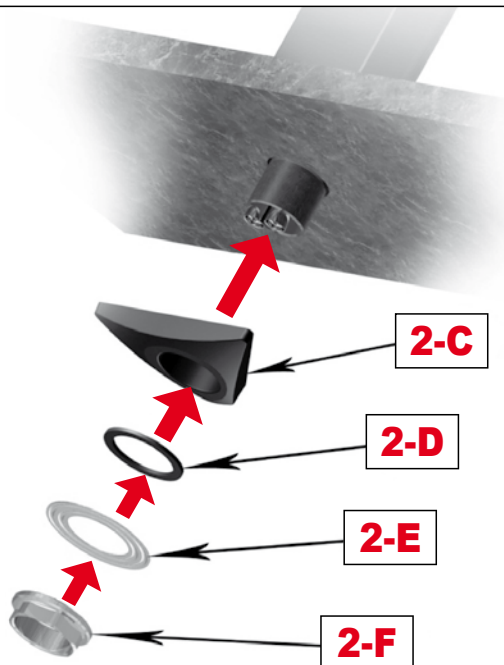

**IT**

Nella parte inferiore del piano, inserire la base appoggio **2-C**, la guarnizione **2-D**, la rondella **2-E** e fissare il corpo avvitando il dado **2-F**.

**EN**

On the underside of the surface, insert the support base **2-C**, gasket **2-D**, washer **2-E** and fasten the body by tightening nut **2-F**.

**FR**

Dans la partie inférieure du plan, introduire la base d'appui **2-C**, le joint **2-D**, la rondelle **2-E** et fixer le bloc en vissant l'écrou **2-F**.

**ES**

En la parte inferior del plano, insertar la base de apoyo **2-C**, la guarnición **2-D**, la arandela **2-E** y fijar el cuerpo enroscando la tuerca **2-F**.

**PO**

Na parte inferior do plano, inserir a base de apoio **2-C**, a guarnição **2-D**, a anilha **2-E** e fixar o corpo apertando a porca **2-F**.

**Fig. 3/3**

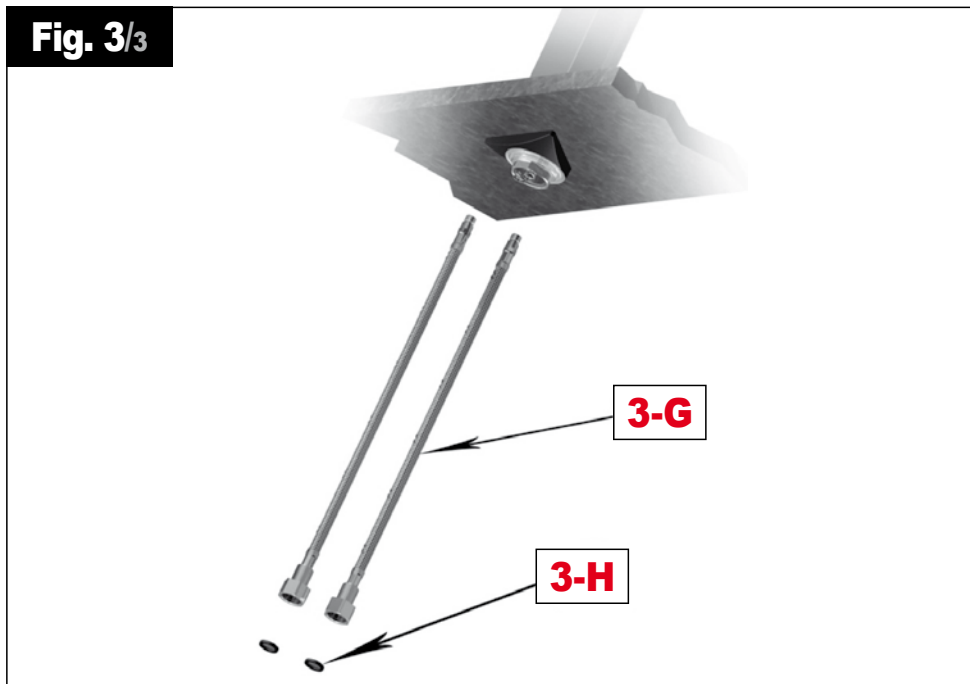

**IT**

Avvitare i flessibili **3-G** alle due cannette del corpo lavabo, collegando il flessibile acqua calda a sinistra e il flessibile acqua fredda a destra. Inserire le guarnizioni con filtro **3-H** e collegare a rete idrica.

**EN**

Fasten the flexible pipes **3-G** to the two mixer tap connecting pipes of the washbasin, connecting the hot water pipe on the left and the cold water pipe on the right. Insert the gaskets with filter **3-H** and connect to the water supply.

**FR**

Visser les flexibles **3-G** aux deux petits tubes du bloc lavabo en reliant le flexible de l'eau chaude à gauche et le flexible de l'eau froide à droite. Introduire les joints avec le filtre **3-H** et relier à l'alimentation en eau.

**ES**

Enroscar los tubos flexibles **3-G** en los dos bastoncillos del cuerpo del lavabo, conectando el tubo flexible del agua caliente a la izquierda y el de la fría a la derecha. Introducir las garniciones con filtro **3-H** y conectarlas a la red de agua.

**PO**

Aparafusar os flexíveis **3-G** aos dois tubos do corpo da pia, unindo o flexível da água quente à esquerda e o flexível da água fria à direita. Inserir as guarnições com filtro **3-H** e ligar à rede hídrica.

**IMPORTANT**

**Pressure & Temperature Requirements.**

- \* Hot and cold water inlet pressures should be equal.
- \* Inlet pressure range: 150-1000 kPa
- \* New Regulation: -500 kPa maximum operating pressure at any outlet within a building. (Ref. AS/NZS 3500.1-2003, Clause 3.3.4)
- \* Maximum hot water temperature: 80°C.



[www.ibrubinetterie.it](http://www.ibrubinetterie.it)

**IB RUBINETTERIE s.p.a.**

via dei Pianotti 3/5  
25068 Sarezzo (BS)  
phone +39 030 802101  
fax +39 030 803097  
[ibrubinetterie@ibrubinetterie.it](mailto:ibrubinetterie@ibrubinetterie.it)  
[www.ibrubinetterie.it](http://www.ibrubinetterie.it)